

WORKSHOP ITEM

Amendment to Chapter 118

Article II, Division 4

“Truck and Hazardous Materials Routes”

No Truck Access

March 5th, 2024

Ordinance Modifications

Staff is planning to bring ordinance modifications to Council for consideration at April 2024 meeting.

It is the intent of this Ordinance Modification is to minimize wear and tear on city streets, to provide for the safety of motorists and residents to reduce noise, vibration, and other ill effects of both large and heavy vehicles and to direct vehicles carrying hazardous materials to streets where such negative impacts will be minimized.

Definition of a Truck

- *Proposed definition:*
- *Truck* means any motor vehicle designed, used or maintained primarily for the transportation of property, equipment, animals, materials, liquids or other goods and having a manufacturer's gross vehicle weight rating exceeding 12,000 pounds.
- *Currently the existing ordinance includes buses or passenger vehicles designed to carry more than 15 passengers in the truck definition. That aspect will be removed from the definition with this ordinance.*

Example Commercial Truck
(not representative of all
commercial trucks)

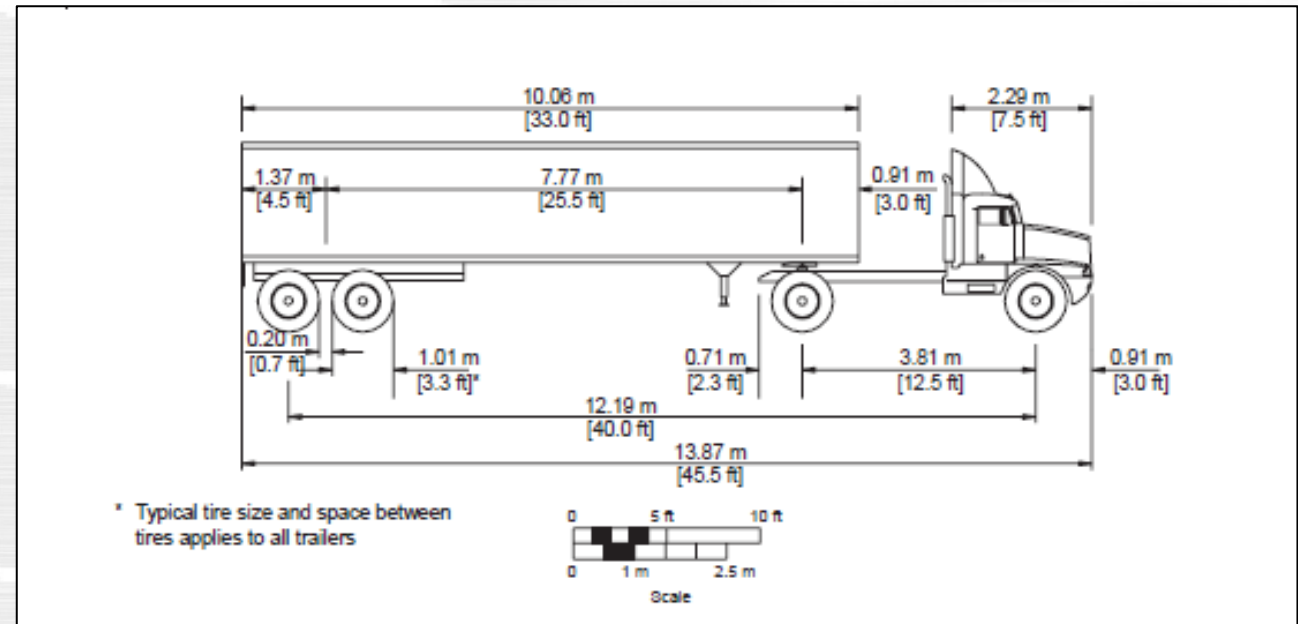

Intermediate Semitrailer
WB-40 Vehicle Dimensions
(AASHTO Green Book)

Parking - Existing Ordinance – Chapter 118

Sec. 118-88. - Parking, standing, or storing of vehicles, trailers.



(a) It shall be unlawful for any person or any owner to leave, park or stand or to permit the parking or standing of any truck or other vehicle with a rated capacity in excess of 12,000 pounds gross vehicle weight, or any other motor home, trailer, truck-tractor, or recreational vehicle upon any public street, or public right-of-way within any part of the city.

It is an affirmative defense to prosecution under this subsection (a) if the vehicle is:

- (1) A recreational vehicle owned by an out-of-town guest of a residential property owner which is parked on the street adjacent to the property owned by such person for a period not exceeding five days;
 - (2) Street construction, maintenance and repair equipment or public service utility company vehicles engaged in repairing or extending public service utilities;
 - (3) Motor buses when taking on or discharging passengers at customary bus stops; or
 - (4) Vehicles designated in this subsection (a) when actually loading or unloading.
- (b) It shall be unlawful for any person or any owner to park, stand, or store or to permit the parking, standing or storing of any vehicle, recreational vehicle, motor home, trailer, boat, truck, or truck-tractor on any portion of a front yard or vacant lot visible from a public place unless:
- (1) Such area is part of a hard-surfaced driveway or parking area; or
 - (2) Such area is a part of a gravel driveway or parking area bordered by cement curbing or similar permanent border to contain the gravel. Provided, however, the use of gravel for the expansion of a driveway or the addition of parking areas on a one-family, two-family or multifamily lot where existing parking areas or driveways are hard-surfaced shall be prohibited.

The term "hard-surfaced" as used herein shall mean an all-weather surface composed of asphalt or Portland cement pavement so as to provide a durable, dustless surface.

This section shall be cumulative of all ordinances of the city except where the provisions of this section are in direct conflict with the provisions of ordinances relating to new construction or overlay districts, in which the conflicting provisions of such ordinances shall control.

- *Existing Ordinance prohibits parking of a truck or truck-tractor on any public street within the City of Bryan.*

Truck & Hazardous Material Routes - Existing

Sec. 118-129. - Truck and hazardous materials routes.



- (a) It shall be unlawful for any person to drive or operate a truck or truck-tractor or any vehicle carrying hazardous materials upon any street within the city that is not designated as a truck and hazardous materials route except as provided below. The following streets within the city limits are designated as truck and hazardous materials routes:
- (1) State Highway 6;
 - (2) State Highway 21, excluding the segment from Farm to Market Road 2818 to State Highway 6;
 - (3) Farm to Market Road 2818 from State Highway 6 to State Highway 21.
- (b) The following streets within the city limits are designated as truck routes only:
- (1) State Highway 21, from Farm to Market Road 2818 to State Highway 6.
- (c) Provided that traveling through residential areas is avoided to the extent non-residential routes are available:
- (1) A truck, truck-tractor or any vehicle carrying hazardous materials may be driven along the shortest route to or from the nearest truck or hazardous materials route to or from the place of business or legally permissible storage area of the owner or authorized operator thereof, or to or from any repair facility, or to or from any commercial truck stop within the city.
 - (2) Trucks, truck-tractors or any vehicles carrying hazardous materials loading or delivering contents or used in providing services at locations within the city may travel to or from the loading, delivery or service location by the shortest route to or from the nearest truck or hazardous materials route. Vehicles making more than one loading stop in the city may proceed from loading stop to loading stop by the shortest route.
 - (3) A truck-tractor without a trailer or any recreational vehicle or personal vehicle, camping or travel trailer combination may be driven by the shortest route to or from the nearest truck or hazardous materials route directly to or from the private residence of the owner or authorized operator thereof.

- *Existing Ordinance defines the only streets that are designated as truck and hazardous materials routes*

Truck & Hazardous Material Route - Exceptions

- *For commercial truck/hazardous material trucks, existing City ordinances do not prohibit the use of the shortest route from the nearest hazardous truck route to the intended place of destination*
 - *This includes loading and unloading stops*
- *This would not change with the proposed ordinance amendments.*

- (c) Provided that traveling through residential areas is avoided to the extent non-residential routes are available:
- (1) A truck, truck-tractor or any vehicle carrying hazardous materials may be driven along the shortest route to or from the nearest truck or hazardous materials route to or from the place of business or legally permissible storage area of the owner or authorized operator thereof, or to or from any repair facility, or to or from any commercial truck stop within the city.
 - (2) Trucks, truck-tractors or any vehicles carrying hazardous materials loading or delivering contents or used in providing services at locations within the city may travel to or from the loading, delivery or service location by the shortest route to or from the nearest truck or hazardous materials route. Vehicles making more than one loading stop in the city may proceed from loading stop to loading stop by the shortest route.
 - (3) A truck-tractor without a trailer or any recreational vehicle or personal vehicle, camping or travel trailer combination may be driven by the shortest route to or from the nearest truck or hazardous materials route directly to or from the private residence of the owner or authorized operator thereof.

Truck & Hazardous Material Route - Exceptions

Sec. 118-130. - Downtown district.



At no time shall any truck, truck-tractor or vehicle carrying hazardous materials be permitted on Main Street in downtown Bryan between 28th Street and 23rd Street. Any vehicle making a delivery or having business in this area shall utilize Bryan Street, Carnegie Alley or the nearest convenient street, alley or parking lot. In the event an operator believes it is necessary for a truck, truck-tractor or vehicle carrying hazardous materials to be upon Main Street for a particular purpose, the operator thereof shall first obtain a special use permit from the city manager or his or her designee setting forth the terms and conditions under which the presence of such vehicle on Main Street will be allowed. In considering whether to grant or deny a request for or establishing terms and conditions of a special use permit the city manager or his or her designee may consider the risk of damage to public or private property, the safety of motorists and persons, any inconvenience to the public, reasonable alternatives available to the operator making the request and any other factors deemed relevant under the circumstances.

- *Existing Ordinance limits Truck access on Main Street*
- *Should use Bryan Avenue, Carnegie Alley or surrounding streets.*

College Station Truck Ordinances

College Station

- Prohibits through truck traffic on any roadway marked with a sign prohibiting truck traffic
- Includes exception for use of shortest path from truck route to place of business
- Recently passed an ordinance to prohibit commercial vehicle parking on public streets city-wide

Sec. 38-201. - No through trucks.

- (a) *Local street prohibition.* It is unlawful for a person to drive or operate a truck or any other motor vehicle with a gross vehicle weight rating (GVWR) of 14,000 pounds or higher on a street described in [Section 38-1009](#) marked with a sign prohibiting through truck traffic.
- (b) *Truck route.* It is unlawful for a person to drive or operate a truck or any other motor vehicle with a gross vehicle weight rating (GVWR) of 14,000 pounds or higher on any other route except for the through route of State Highway 6.
- (c) *Affirmative defenses.* It is an affirmative defense to prosecution under this section that:
 - (1) The person is operating the truck or motor vehicle that is going directly to or from a residential or business address on prohibited street to deliver or pick-up material and the driver or operator has proof of the delivery or pick-up.
 - (2) The person is using the truck or motor for a private purpose not including the transporting, loading, or unloading of material or property.
- (d) *Non-applicability.* This section does not apply to person driving or operating a truck or motor vehicle that is:
 - (1) Owned by a governmental entity,
 - (2) Owned by a public or private utility,
 - (3) Engaged in the business of transporting people, or
 - (4) Parked at the owner's or lessee's residence or place of business.

New - Trucks prohibited on certain streets

- The amendment to the ordinance lists specifically the streets that truck or truck-tractors may not operate on.
- These are typically residential roadways, many narrow, and some not providing enough room for a truck to maneuver or turn around.

Sec. 118-135. – Trucks or truck-tractors prohibited on certain streets.

- (a) It is unlawful for any person to drive or operate a truck or truck-tractor on any street, roadway, or highway within the city limits when such street is marked with a sign prohibiting truck traffic on those streets or portions of streets as follows:
- (1) Suncrest Street from Beck Street to West 28th Street
 - (2) Bittle Lane from Leonard Road/Groesbeck Street to Finfeather Road
 - (3) West 14th Street from North Sims Avenue to North Parker Avenue
 - (4) Colson Road from Clarks Lane to State Highway 6 Frontage
 - (5) North Washington Avenue from North Texas Avenue to East 16th Street
 - (6) East 15th Street from Texas Avenue to North Tabor Avenue
 - (7) South Baker Avenue from East 29th Street to East 30th Street
 - (8) East 30th Street from South Houston Avenue to South Hutchins Street
 - (9) South Hutchins Street from East 29th Street to East 30th Street
 - (10) Tee Drive from Wellborn Road to Green Street
 - (11) July Street from East William Joel Bryan Parkway to Rose Street
 - (12) North Rosemary Drive from South Texas Avenue to East 29th Street
 - (13) Bruin Trace from West Martin Luther King Jr. Street to Saunders Street

Exceptions

- These are new proposed exceptions

(b) It is a defense to prosecution under this section that the truck or truck-tractor is:

- (1) making a delivery or pick-up from a residence, business, or construction site located on said street, roadway, or highway;
- (2) owned, leased by, or in the service of a government entity;
- (3) owned or leased by a public utility in the performance of its duties;
- (4) engaged in the business of transporting people;
- (5) an emergency vehicle en route to or returning from an emergency; or
- (6) en route to or returning from a residence located on a street listed in subsection (a) of this section that is owned or leased by the vehicle's operator.

Strengthened Hazardous Material Requirements

- New amendments will add requirements for documentation and that must be available when requested.

- (a) It is unlawful to drive or operate a truck, truck-tractor, or vehicle carrying hazardous materials within the city limits without having in possession an appropriate license for the type of vehicle and load, bills of lading, or similar documents showing the destination and contents being hauled, to the extent such documentation is required under applicable laws or regulations.
- (b) All documents must be provided to any certified peace officer or any fire department personnel when applicable for inspection upon request.

Signage - Selective Exclusion Signs

- Per the Texas Manual on Uniform Traffic Control Devices (TxMUTCD)
 - Support:
 - Selective Exclusion signs (see Figure 2B-11) give notice to road users that State or local statutes or ordinances exclude designated types of traffic from using particular roadways or facilities.
 - **Standard:**
 - **If used, Selective Exclusion signs shall clearly indicate the type of traffic that is excluded.**

Support:

- 03 Typical exclusion messages include:
- A. No Trucks (R5-2, R5-2a),
 - B. NO MOTOR VEHICLES (R5-3),
 - C. NO COMMERCIAL VEHICLES (R5-4),
 - D. NO TRUCKS (VEHICLES) WITH LUGS (R5-5),
 - E. No Bicycles (R5-6),
 - F. NO NON-MOTORIZED TRAFFIC (R5-7),
 - G. NO MOTOR-DRIVEN CYCLES (R5-8),
 - H. No Pedestrians (R9-3),
 - I. No Skaters (R9-13),
 - J. No Equestrians (R9-14), and
 - K. No Hazardous Material (R14-3) (see Section 2B.62).

Figure 2B-11. Selective Exclusion Signs

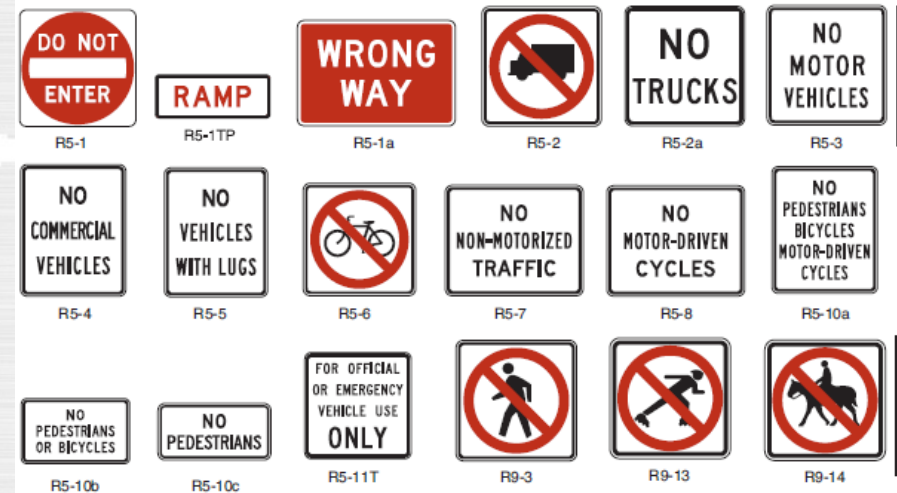

A large, stylized graphic of the letters 'R' and 'B' in white, set against a light blue background. The 'R' is on the left and the 'B' is on the right, with a vertical line separating them. A white star is positioned in the lower right quadrant of the 'B'. A dark blue horizontal bar is at the top of the image.

Questions?

Narrow Streets



Main Street from
28th Street to MLK Jr Street



Bittle Lane from
Leonard Road to Finfeather Road

Residential Streets



Esther Boulevard from
East 29th Street to Twin Boulevard



Tee Drive from
Wellborn Road to Green Street